

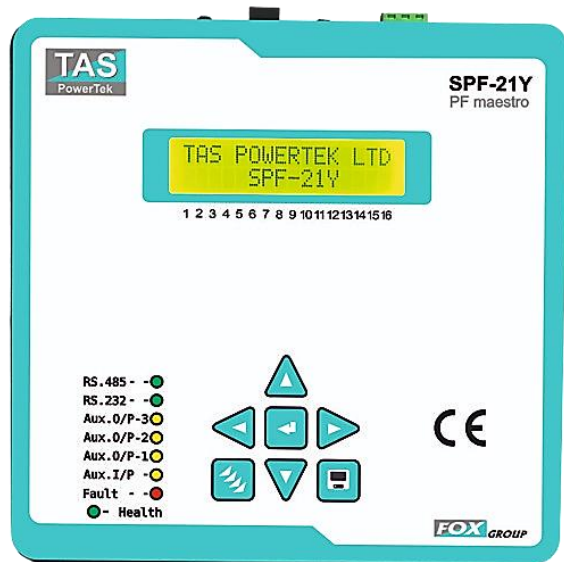

# Product Data Sheet

## PF maestro – SPF-21YE Series Power Factor Controller



**PF maestro – SPF-21YE Series** is a next-generation intelligent 1CT & 3CT real-time power factor controller designed to deliver precision fundamental reactive energy control, kVAH billing optimization. It offers real-time measurement of supply, ensuring unparalleled accuracy, system harmonic analysis up to the 31st order, and programmable control modes, this product series adapts seamlessly to both low voltage and medium voltage power networks and maximum demand control indication.

### PRODUCT FEATURES

- **Real-time Automatic Displacement Power Factor (D-PF) Correction**  
SPF-21YE intelligently switches capacitor banks to maintain a programmable target PF up to three decimal places, ensuring optimal energy efficiency, improved voltage stability, and reduced utility penalties across dynamic industrial loads.
- **Demand Controller with Programmable Integration Window and kW Limit**  
Monitors active power demand (kW) with Class 1.0 accuracy, applying an adjustable integration window from 1 to 60 minutes to detect peaks early and selectively disconnects capacitor banks or activates auxiliary relay outputs to shed external loads, enabling users to avoid exceeding contractual maximum demand limits without manual intervention while maintaining plant reliability.
- **Comprehensive Electrical Parameter Measurement**  
Continuously measures Voltage, Current, Active Power (kW), Reactive Power (kVAR), Apparent Power (kVA), Distortion Power (D,Dx), Frequency (45–65Hz), Power Factor (DPF & PF), and Harmonics (up to 31st order). This is under IEC-62053 part 21 & 23 Class 1.0 accuracy, providing a comprehensive overview of power system performance and power quality.
- **Auxiliary Control Voltage Monitoring for Enhanced System Protection**  
Monitors auxiliary supply voltage used for capacitor switching contactor coils. It inhibits capacitor switching during low-voltage events, preventing harmful contactor chattering, coil overheating due to over-voltage and premature mechanical or electrical failure of critical panel components like cooling fans, instrumentation supply etc., thereby extending the lifetime various devices within Auto PF correction system.
- **Programmable Capacitor Discharge Time Enforcement**  
Ensures safe capacitor recharging by applying programmable discharge delays between 2 and 7299 seconds, which prevents reconnection under residual voltages, thereby protecting capacitors, contactors, and overall system stability during rapid compensation cycles.
- **Capacitor Step Utilization Tracking and Predictive Maintenance Support**  
Tracks switching ON counts and cumulative ON-time in minutes for each capacitor step, calculating a Utilization Count that enables predictive maintenance scheduling, thus preventing unexpected step failures and maximizing the lifespan of capacitors, detuned reactors and switching devices.

- **Capacitor Health Monitoring Without Additional Current Sensors**  
Analyzes VAR contribution per switching operation to detect faulty capacitors without needing extra CTs, saving installation costs while maintaining system integrity.
- **Advanced Harmonic Distortion Monitoring up to 31st Order**  
Measures voltage THD% and current TDD% harmonic levels. It even monitors the capacitor current THD% & values. Detects and helps mitigate harmonic-related power quality issues, protecting system components.
- **Flexible Wiring Topologies with Automatic Adaptation**  
Supports 3CT/4Wire, 2CT/3Wire, and 1CT/2Wire configurations, allowing easy adaptation to standard LV panels or transformer secondary monitoring without special rewiring, making installations faster, safer, and more cost-efficient.
- **Automatic and Manual Current-Voltage Wiring Synchronization**  
Corrects CT polarity, phase sequencing and capacitor bank sizing internally without requiring rewiring, reducing installation errors and commissioning time. Additionally provides the facility to manually synchronize the voltage and current connections without physical wiring termination change.
- **Wide Auxiliary Supply Range of 90-485V AC**  
The wide voltage range ensures the meter continues to function safely even during voltage fluctuations, preventing unexpected shutdowns or failures that could lead to electrical hazards, overheating, or damage to connected equipment.
- **Advanced Fault Detection with Programmable Fault Handling**  
Advanced monitoring of over 100 fault & events conditions critical to power factor correction systems, including undervoltage (UV), overvoltage (OV), overcurrent (OC), earth faults, auxiliary voltage loss, and over-temperature conditions. With programmable fault handling, users can define specific response action - Log Only, Normal Trip, or Instant Trip to align with system importance and safety. The fault limits and resume limits setting as per site conditions ensures safe, efficient operation of the APFC panel.
- **User-Friendly 2-Line LCD Display with 7-Key Navigation Keypad**  
Facilitates easy parameter viewing and device configuration even in poor lighting conditions.
- **Rugged IP54 Fire-Retardant Housing with Full Compliance**  
Engineered with fire-retardant ABS material, IP54 front protection, and compliance with IEC 61326-1 EMC, CE, and RoHS3 standards, ensuring reliable and safe operation in harsh industrial conditions.

## TECHNICAL SPECIFICATIONS

Function	Parameter	Condition	Minimum	Maximum
<b>Measurement</b>				
<b>Supply</b>	Voltage (V) Sinusoidal	3-Phase & Neutral - fundamental 3-Phase (3-wire) - fundamental 2-Phase - fundamental 1-Phase & Neutral - fundamental	50V~ L-N 85V~ L-L 85V~ L-L 50V~ L-N	315V~ L-N 550V~ L-L 550V~ L-L 315V~ L-N
	Current (I) Sinusoidal	5 Amp IN: - fund. 1 Amp IN: - fund.	75mA(cl-2),5mA-min 200mA(cl-2),5mA-min	7.5 Amp 1.5 Amp
	Frequency	Frequency (Hz) (Fundamental Supply Voltage measurement of frequency)	47Hz (for 50Hz) 57Hz (for 60Hz) meas range 45Hz	53Hz (for 50Hz) 63Hz (for 60Hz) meas range 65Hz
	Power / Energy	IEC-62053 pt.21 & 23 4 quadrant measurement	5Amp range: Class 2: P & Q 1Amp range $\geq$ 200mA: Class 2 P & Q	
	Maximum Demand	S (VA) } 1 min sliding window P (W) } Window time user set.	Window time 5 - Minutes	Window time 60 - Minutes
	Harmonics	Voltage - L-L & L-N Current - per L (RYB) & N	Spectrum: 2nd to 31st Harmonic. For Voltage and Current.	
	VA Burden	Voltage at 550V~ L-L Voltage at 415V~ L-L Current at 7.5Amp~ S-CT Current at 5.0Amp~ S-CT Current at 1.0Amp~ S-CT	<1.13VA per ph., <3.40VA total 3-ph <0.65VA per ph., <1.95VA total 3-ph <1.0VA per ph., <3.0VA total 3-ph <0.5VA per ph., <1.5VA total 3-ph <0.05VA per ph., <0.15VA total 3-ph	
<b>Capacitor Control</b>				
<b>PF Correction</b>	Target PF	Displacement Power Factor setting	Inductive: 0.000	Capacitive: 0.000
	VAR margin	Smallest capacitor bank VAR ... X	... X 1.1	... X 9.9
	Offset to target	% above the target PF setting	0%	100%
<b>ON/OFF control</b>	Algorithm	Optimal value to target.	Single target PF with adjustable No action VAR tolerance band	
	Bank Utilization	<b>Limit</b> = (Number of switch ON / <b>C</b> ) + (On duration in Minutes / <b>T</b> )	C = 01 (00 for Disb.) T = 01 (00 for Disb.)	C = 99 T = 99
	High Speed Pull-up Solid State switching	Group of 5 numbers (3-groups) + Transistor switched high speed on/off	Voltage: +10Vdc Amp: 0mA dc	Voltage: +24Vdc Amp:30mA dc(<2.5Vdrop) Current limit 32-40mA

Auxiliary Supply				
Voltage	AC supply	for energizing unit	90 V~	485 V~
	DC supply		100 V	550 V
VA consumption	AC supply VA	90V~: 485V~: metering	--	7.5 VA
		With full Control loading	--	15.0VA
	DC supply VA	100V --- to 550V --- metering	--	7.5 VA
		With full Control loading	--	15.0VA
Auxiliary Functions				
Add-on Fault detection:	Actions	On exceeding the user set conditions	Indicative: Data Log: LDATA Capacitor Regular trip: NTRIP Capacitor Instant trip: INS-X	
	Recovery	Automatic Timer Reset Manual intervention Reset	Depending upon fault type. (Refer details in the further part of this document)	
Auxiliary Input	Voltage~ Rating	AC supply input (abs. max. rating) AC measurement range Digital range	0 - (Zero) Volt ~ 68 Volt ~ 0 (Zero): < 3 Volt~	300 - Volt ~ 290 Volt ~ 1 (One): > 68 Volt ~
Auxiliary Output	NO contact	AO1 & AO2	5Amp Resistive / 0.5Amp Inductive Amp~ 250V~ voltage contact rating.	
	Transistor	AO3	High Speed Pull-up Solid State switching +10Vdc to +24Vdc up to 30mA (<2.5V drop) output with current limit. (32mA to 40mA current limit)	
Enclosure / Display / Keyboard / Connectors				
Enclosure	Type	Fire retardant ABS grade		
	Dimensions	Front Facia dimensions + depth Panel cutout dimensions	146 (H) x 146 (W) x 75 (D) mm 138 x 138 mm	
	Weight	Unpacked unit weight Packed unit weight	< 0.9 KG including mounting clamps <= 1.25 KG	
	IP Class	Front Facia: Back side - Inside Panel:	IP-54 IP-20	
Display	LCD backlit	Yellow-Green with LED Backlit	16 Graphic Character X 2 Lines	
	Contrast/view	Adjust Min - Max 25 key presses	Left key: Lighter	Right key: Darker
Keyboard	Isolated tact switch	7 - Key - User Friendly	Up, Down, Left, Right : 4 Navigation keys Enter: For value entering Selection: Mode & Parameter selection Save: Saving key	
Connectors	Plug - Socket	Voltage Measuring Current (supply & cap) Measuring Output Control & Aux control Communication & Pt-100	7.62mm pitch - Pin type lugs tightening 5.08mm pitch - Screw lockable plug-socket 7.62mm pitch 3.81mm pitch	

Temperature sensing				
<b>Internal unit temperature</b>	For Unit right functioning	Range within unit operating temperature	0°C	+65°C
Environmental / Safety - Type tests				
<b>IEC61326-1</b>	EMC	Electromagnetic Compatibility	Compliance	
	EMI	Electromagnetic Interference	Compliance	
<b>IEC61010-1</b>	Safety Standards	Safety Standards with Low Voltage instruments directive (category III)	Compliance	
<b>RoHS</b>	2002/95/E C RoHS 3.0	Regulation on Hazardous Substances usage.	Compliance	
<b>CE</b>			Compliance	
<b>IEC60068-2</b>	Dry Heat	Storage condition +70°C for 72Hrs	Compliance	
	Cold Test	Storage condition -25°C for 72Hrs	Compliance	
	Damp Heat Cyclic Test	Power-up condition At RH 93% +40°C & +25°C 12-12Hrs. cyclic 144Hrs.	Compliance	
<b>Temperature</b>	Operating	Surrounding Ambient temperature	0°C	+60°C
	Storage	Surrounding Ambient temperature	-10°C	+70°C
<b>Humidity</b>	RH%	Relative Humidity	10%RH	95%RH (non-cond.)

All specifications are typical and subject to change without notice due to ongoing product development and improvement.

## WIRING TERMINALS

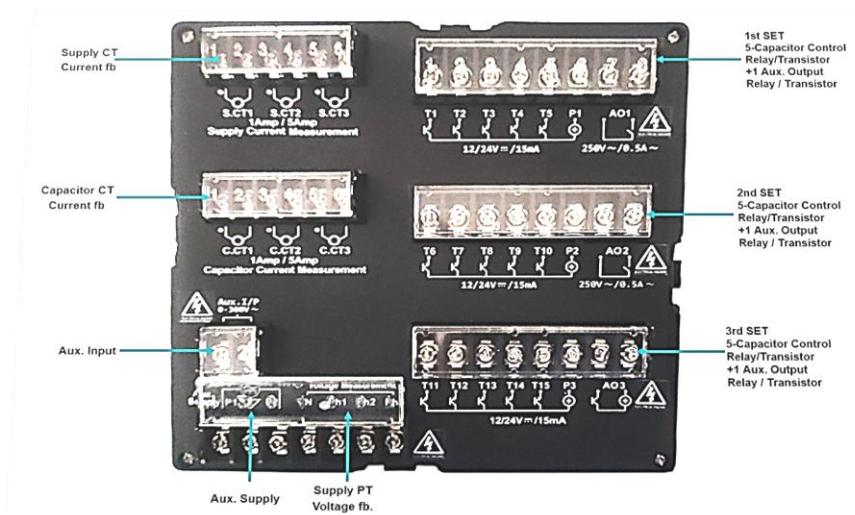

Serial Communication Termination Block



External Temperature Sensor RTD input. PT100 (3-wire)

MECHANICAL DIMENSIONS

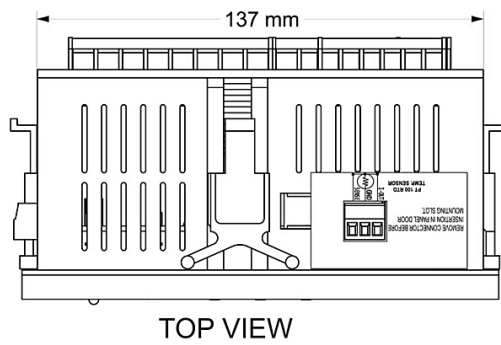
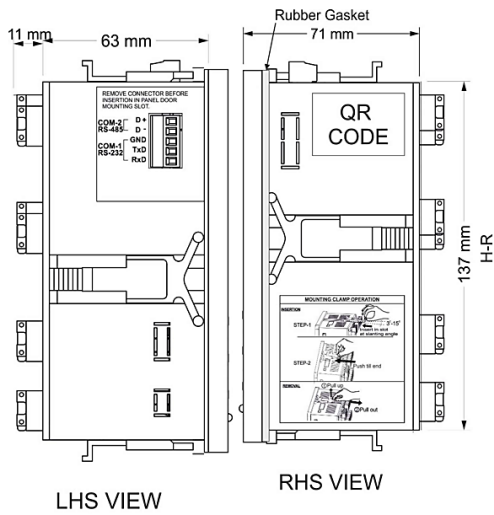
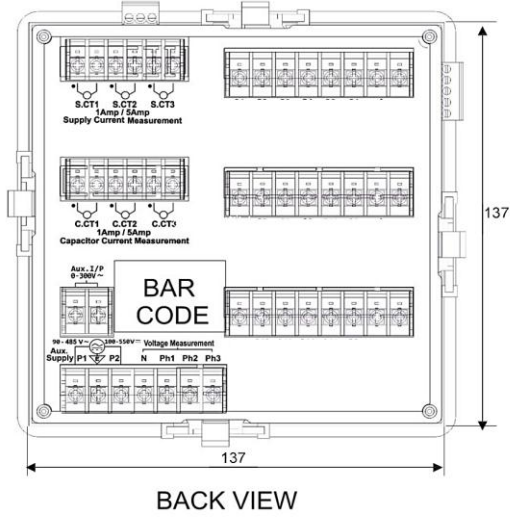
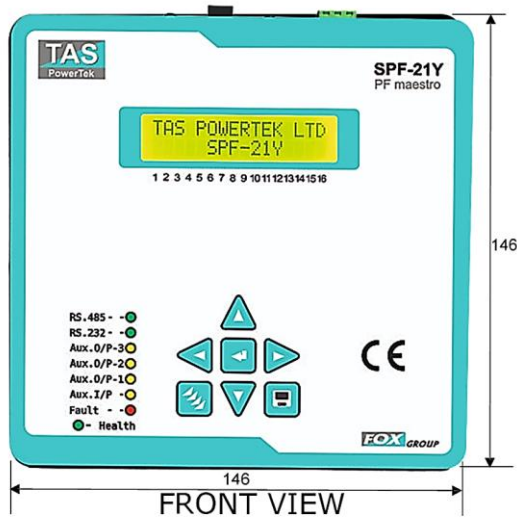

WIRING RECOMMENDATIONS

Connections with Low Voltage supply:

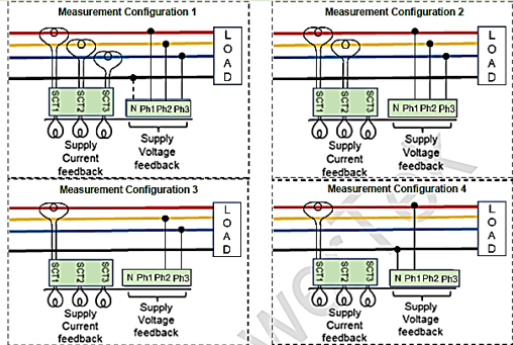

Connections with High Voltage supply:

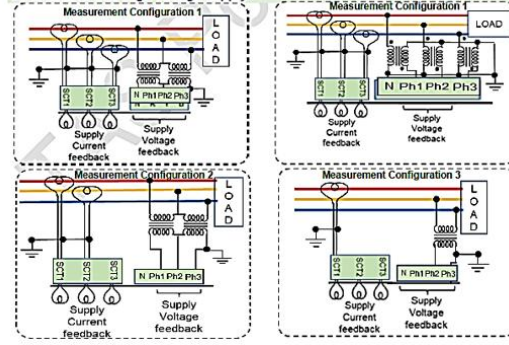

PRODUCT SELECTION AND FEATURES

Features/Models		SPF-21Y/FK3NNNO	SPF-21Y/FT3NNNO	SPF-21Y/AK3NNNO	SPF-21Y/AT3NNNO	SPF-21Y/FK1NNNO	SPF-21Y/AK1NNNO
PFC HARDWARE FEATURES	Steps	16	16	11	11	16	11
	Mounting dimensions 144 X 144	√	√	√	√	√	√
	Step switching Relay (R)	√	X	√	X	√	√
	Step switching Transistor (T)	X	√	X	√	X	X
	Supply Current Measurement 3-CTs	√	√	√	√	X	X
	Supply Current Measurement 1-CT	X	X	X	X	√	√
	Internal Temperature sensing within MCU	√	√	√	√	√	√
	Auxiliary Dig. Inputs	√	√	√	√	√	√
	Auxiliary Digital Outputs	√	√	√	√	√	√
MEASUREMENT & DISPLAY	Supply freq. phase locked measurement	√	√	√	√	√	√
	Voltage meas. 4W, 3W, 2WLL, 2WLN	√	√	√	√	X	X
	Power meas. 3Watt-met, 2Watt-met, 1Watt-met	√	√	√	√	X	X
	Supply RMS Current measurement	√	√	√	√	√	√
	Supply RMS Voltage measurement	√	√	√	√	√	√
	Volt/Amp/Cap-ind. Volt & Amp fundamental values	●	●	●	●	●	●
	Power Distortion & Cross distortion values	√	√	√	√	√	√
	Minimum supply current sensitivity 0.001% of rated	√	√	√	√	√	√
	Frequency range 45Hz to 65Hz	√	√	√	√	√	√
	P,Q,S RMS 3-phase overall Values	√	√	√	√	√	√
	P,Q,S Fundamental 3-phase Overall Values	√	√	√	√	√	√
	Ph,Qh,Sh + & - RMS Energy	√	√	√	√	√	√
	Ph1,Qh1,Sh1 + & - Fund. Energy	√	√	√	√	√	√
	Maximum (+/-) values of various measured parameters	√	√	√	√	√	√
	Maximum Demand KVA & KW-user set sliding window	√	√	√	√	√	√
	Supply Voltage harmonics THD-% & value	√	√	√	√	√	√
	Supply current harmonics THD% & TDD%	√	√	√	√	√	√
	Volt & Amp, C/I.Amp harmonic spectrum up to 31st	●	●	●	●	●	●
	AC voltage meas. with aux.i/p (contactor coil)	√	√	√	√	√	√
	PFC internal operating temperature	√	√	√	√	√	√
Capacitor steps VAR on-line detection (normalized)	√	√	√	√	√	√	
Capacitor steps Utilization (switching & time)	√	√	√	√	√	√	
PFC powering up/down counter	√	√	√	√	√	√	
RELIABILITY FEATURES	PFC power voltage 90V~ to 485V~ (Max limit 600V~)	√	√	√	√	√	√
	EMI filter for transient protection on PFC power supply	√	√	√	√	√	√
	Early Warning Power Fail detection for data loss	√	√	√	√	√	√
	Capability to work in Dusty & Conductive environment	√	√	√	√	√	√
	Operability at -10°C to +60°C ambient temperature	√	√	√	√	√	√
	S/c protected sourcing / sinking current Transistor o/ps	X	√	X	√	X	X
	Fire retardant material housing	√	√	√	√	√	√
	Housing Front facia IP-54, Back IP-30	√	√	√	√	√	√
FAULT MONITORING & CAP.TRIPPING	Contactors coils voltage over / under value	√	√	√	√	√	√
	Over & Under Voltage on meas. Voltage	√	√	√	√	√	√

	Features/Models √ - Available X - Not Available • - Optional	SPF-21Y/FK3NNNO	SPF-21Y/FT3NNNO	SPF-21Y/AK3NNNO	SPF-21Y/AT3NNNO	SPF-21Y/FK1NNNO	SPF-21Y/AK1NNNO
<b>FAULT MONITORING &amp; CAP.TRIPPING</b>	PFC power shutoff protection for excess Over-voltage	√	√	√	√	√	√
	Supply Voltage Over-frequency and Under-frequency	√	√	√	√	√	√
	Capacitor step VAR health monitor & selective trip	√	√	√	√	√	√
	Capacitor step user masking	√	√	√	√	√	√
	Supply Voltage, Current Over-harmonics	√	√	√	√	√	√
	Capacitor step over-utilization selective trip	√	√	√	√	√	√
	PFC electronics & memory self-monitoring faults	√	√	√	√	√	√
	Over Temperature internal to PFC unit	√	√	√	√	√	√
<b>ALARMS &amp; AUX.Function</b>	Fan control by over temperature	√	√	√	√	√	√
	Step/s declared faulty & masked	√	√	√	√	√	√
	Indicative Fault / Event alarm	√	√	√	√	√	√
	Step/s (1 or more) trip alarm	√	√	√	√	√	√
	Auto-synchronization failure alarm	√	√	√	√	√	√
	Unit functioning without any fault indicator	√	√	√	√	√	√
<b>APPLICATION FEATURES</b>	EASY EDIT settings for standard LV usage	√	√	√	√	√	√
	HV APFC system usage	√	√	√	√	√	√
	Steps Capacitor testing mode	√	√	√	√	√	√
	Fixed capacitor banks step declaration by user	√	√	√	√	√	√
	Fixed or Proportionate Correction time - user set	√	√	√	√	√	√
	Mono-phase compensation with Cap & Ind. VAR	√	√	√	√	X	X
	Inductive VAR compensation for 3-ph & per-ph.	√	√	√	√	√	√
	User friendly Keyboard for front operations	√	√	√	√	√	√
	Capacitor step status on front LCD	√	√	√	√	√	√
	Adjustable C/K: Offset & VAR band width to Target PF	√	√	√	√	√	√
	Automatic Supply V & A synchronization	√	√	√	√	√	√
	Automatic step VAR detection	√	√	√	√	√	√
	Manual wiring V & A synchronization	√	√	√	√	√	√
	Expansion of steps by additional module	√	√	√	√	√	√
	Dual PF settings for Generator & Grid supply	√	√	√	√	√	√
	Voltage & Current sensing on 2 sides of transformer	√	√	√	√	√	√
	HV side sensing and LV side compensation	√	√	√	√	√	√
	LV side sensing & compensation with HV side control	√	√	√	√	√	√
	4-quadrant operation for Solar/Wind generation	√	√	√	√	√	√
	High speed cycle to cycle control with Thy.version	X	√	X	√	X	X
	Two X'mer with 2 APFC with bus coupler operation	√	√	√	√	√	√
	Monthly auto reset of MD / Energy values	√	√	√	√	√	√
	Password protected user settings	√	√	√	√	√	√
"I AM OK" self-monitoring health indicator (LED / LCD)	√	√	√	√	√	√	
<b>TYPE TEST CERTIFICATIONS</b>	CE/RoHS	√	√	√	√	√	√
	EMC/EMI	√	√	√	√	√	√
	SAFETY Voltage category III	√	√	√	√	√	√
	Environmental & IP Enclosure	√	√	√	√	√	√
	Accuracy of Measurement as defined	√	√	√	√	√	√
	Galvanic isolation insulation standards	√	√	√	√	√	√
	Storage	•	•	•	•	•	•